

When the computer enables freedom from the machine

(On an outline of the work *Hérédo-Ribotes*)

Fabien Lévy¹
composer

abstract

In some cases, when the musical process is sufficiently verbalised and formalized, the computer allows the composer to concentrate on the music and to spend time on the calculation. I will show a very simple example of technique used in my orchestral work Hérédo-Ribotes for viola solo and fifty-one orchestra musicians, and illustrate the aesthetic ideas underlying this piece. I will also show different cases in which the computer was a good musical assistant in the production of this esthetical meaning, and in which it was, on the contrary, better by hand.

As far as I'm concerned, it is extremely difficult for a composer to limit a musical intention to formalised and verbalised procedures, because aesthetic effect is more valuable than technical skill. Apart from the fact that an intention cannot always be rendered explicit, a technique's effect is interesting only if one reaches beyond, so to speak, the kitchen utensils in order to engage with the chef's aesthetic, and even with his political obsessions. With this in mind, I will present my personal use of the *Open Music* software according to two considerations. The first consideration is epistemological, and I will show that rather than restraining the composer to making purely technical considerations, the use of computers in musical composition enables him/her to free him-/herself from such limitations. The second consideration is aesthetic, and I will attempt to describe succinctly the artistic reflections that motivate my computer-based procedures presented here.

1) A generation of paradox

The composers who, like me, were born around 1968 are neither members of the generation who were in their twenties at the end of the Second World War (Boulez, Ligeti, Stockhausen, Xenakis,...) nor of the generation for whom the events of 1968 were defining moments of their adolescence (Ferreghetti, Grisey,...). This accounts for one of the traits of my generation: that we are generally detached from the attitudes of refusal of the past that marked the former generation or of systems that distinguished the latter. Many of us, however, have inherited from our "musical grandparents" the desire to construct new grammars and share with our "parents" the dream of developing new concepts that go beyond the sign and analytic thought². But in this so-called "postmodern" era, some among us are wary of notions of stylistic progress, preferring instead notions of sincerity and originality, just as we are wary of the idea of universal perception, favouring instead the idea of cultural listening conventions to be interrogated and deconstructed. Personally, I prefer paradox to forms and processes that are overly demonstrative. In fact, on the level of technique alone, I was exposed to computers at an early age³. However, perhaps because I became familiar with computers at an early age, I strongly demystify the contribution of technology to the creative act, composing everything by hand, and more so, mentally.

2) Transparametric techniques

One of the recurring questions in my work deals with the closure of analytic thinking and perception⁴. From 1996 onwards, I began to think hard about the notion of transparametric musical inflexion— research into

¹ Thanks to Christian Pinawin for the help in the translation into English

² Analytic thought is characterised in Western music in particular by a separation of musical parameters in rhythm, pitch, and duration, by a reduction of complex, continuous phenomena to finite, discontinuous alphabets, by functional thought, and consequently by thinking the sign combinatorially.

³ When I was eleven, I was playing on a elementary ZX80 Sinclair computer; a few years later I performed my first experiments in computer music with the Yamaha CX5M musical computer and in programming (BASIC, and then PASCAL). I pursued advanced coursework in the sciences at the same time as my studies in music

⁴ Perception and writing are closely linked, and to work on the closure of one has implications for the deconstruction of the other. We think according to how we perceive and represent the world; likewise, we perceive according to how we

the smallest musical tensions, where the action would be detected by the senses but not intelligible or analysable, and in particular, not reducible to a transformation according to any of the traditional parameters of Western music – duration, pitch and intensity. The challenge was to construct musically moments of *presque rien* and *je ne sais quoi*, to use Jankelevich's expressions. I borrowed, for my instrumental music, an acoustic principle which was associated with analogue samplers, bringing together in the same relation the frequency of transposition and the pulsational speed of a sound. This technique was already used by Karlheinz Stockhausen (*Kontakte* 1960; see also his article *Wie die Zeit vergeht*, 1957), but with a different objective – so that the serial differentiation of pitches reflects that of rhythms. In my work, this principle allows, on the contrary, the concealment of the parametric origin of a phenomenon: an infinitesimal variation in pitch, for example the transposition of a quarter-tone of a musical element, would be systematically accompanied by a change of the same order to the other parameters, particularly to the speed of rhythmic repetition of this element (figure 1). The accumulation of these tiny inflexions applied to all parameters in similar ratios would create a tension without one's perceiving its analytic cause.

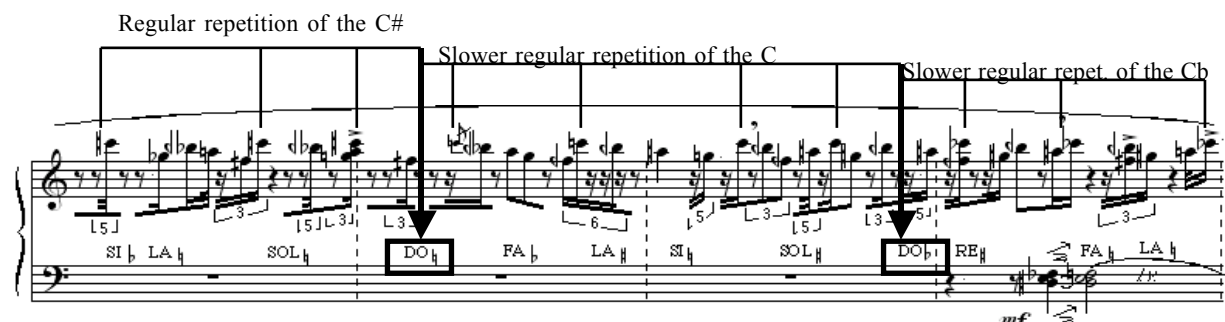

Fig 1. Technique of transparametric musical inflexion: extract from *Les deux ampoules d'un sablier peu à peu se comprennent* (1996), for amplified solo harp (Billaudot publisher).

It should be made clear that in order to develop this technique⁵ and to assess its aesthetic consequences, it was initially necessary to work on it manually, determining what it put at stake as well as its musical consequences due to the sluggishness of transcribing first onto graph paper and then to music manuscript paper. It was only when this technique was properly verbalised and formalised, when its aesthetic stakes were mastered, and when my research began to shift focus to other techniques, making it necessary that no more time should be spent on calculations of transparametric pulsations that I decided to program the technique on *Open Music*.

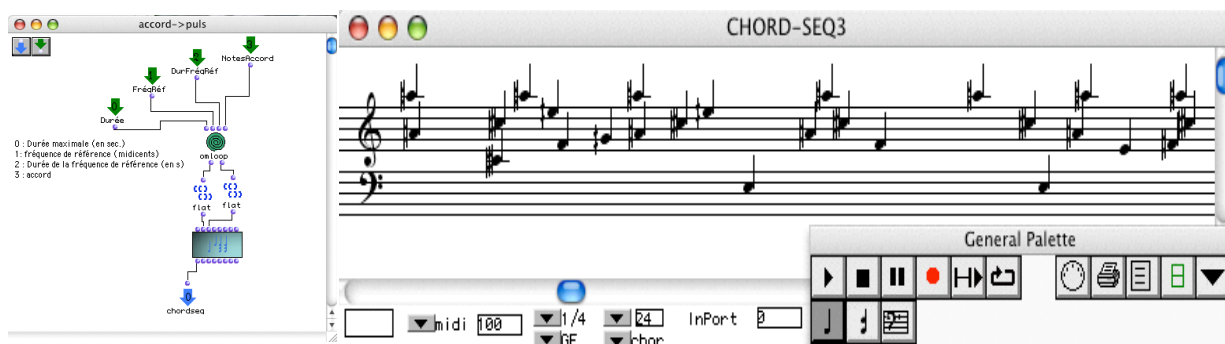

Fig 2. Formalisation of the technique of transparametric musical inflexion: patch programmed on *Open Music* software (at left) and example of a result (at right, sketch from *Hérédoribotes*, for solo viola and 51 orchestra musicians, mes. 210)

think, for example by focusing in the West on the fundamental – or tone – of a complex sound, by separating the parameters of listening, by instinctively hearing tonal functions, etc.

⁵ The technique itself remains somewhat naive; but seen from a strictly algorithmic point of view, so too do the techniques of derivation of dodecaphonic series, the production of spectra or the canon.

3) Passage to the machine

The formalization of such a technique on *Open Music* raises numerous interesting issues. In the pieces that followed *Les deux ampoules d'un sablier peu à peu se comprennent*, I focused more upon the “styling” of the cloud of points obtained by the technique of transparametric inflexions. The task was to give form and colour to each of the tiles of the mosaic, so that one’s perception would be lost between totality and detail. This reflection on confusion is a prior step in the deconstruction of analytic thought in music. So I needed a simple, effective tool that allowed me to create the cloud of points and their different inflexions and to hear them immediately, like a composer searching for and selecting chords at the piano. *Open Music*, with its musical interface, its capacity to hear immediately in quarter-tones, its double representation of music – metric (in the form of *voice*) and proportional (in the form of *chordseq*) was the ideal tool.

The other noteworthy property of *Open Music* is its structure in patches of patches, in abstraction of abstractions, very close to a composer’s thoughts: once a technique is established, the composer reuses it often in slightly modified configurations or integrates these configurations into more extensive techniques. The capacity to transform a patch into a functional abstraction, that is, to transform certain data into variables in *Open Music*, and the possibility to insert a patch into another encourages this compositional practice.

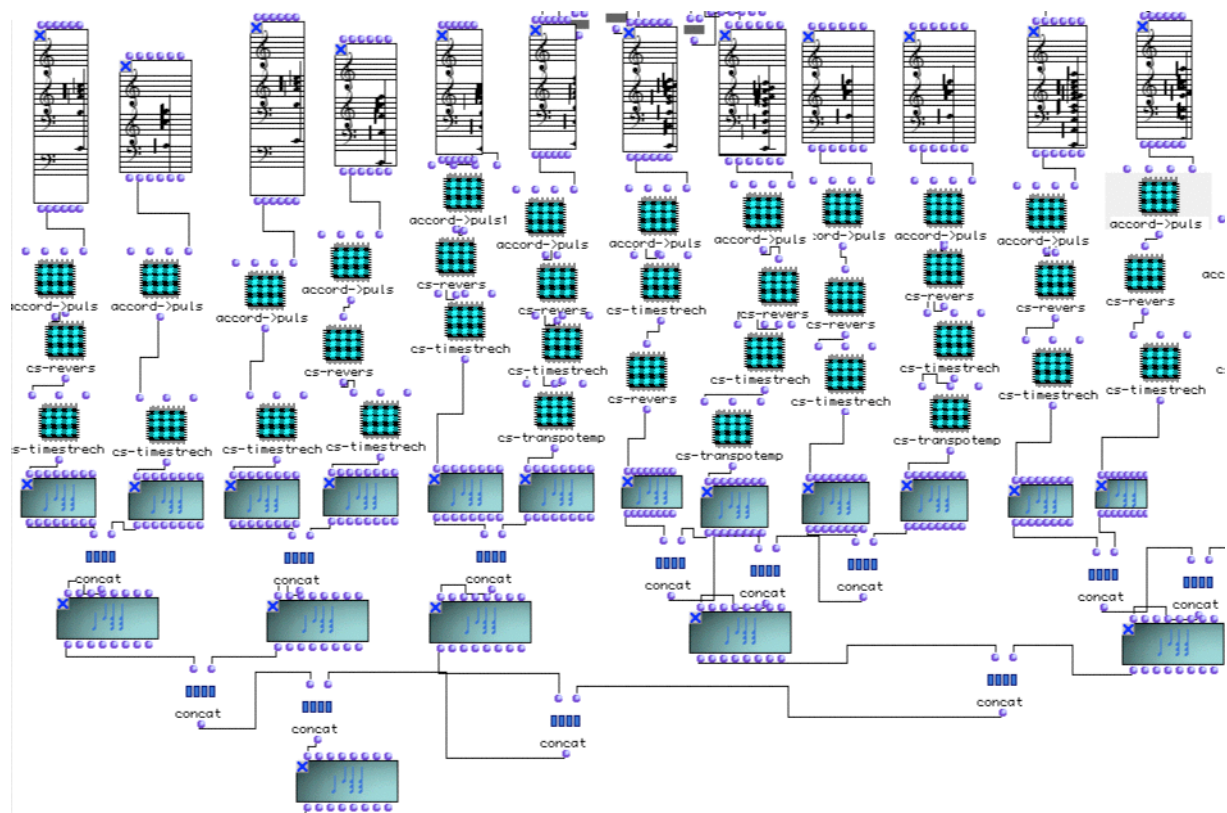

Fig 3. combination and abstraction of Patches in *Open Music* : sketches for *Héredo-Ribotes*, for solo viola and 51 orchestra musicians (mes. 169 à 219)

4) On the utility of manual labour

Once the cloud of points has been calculated by the computer, one must evidently render it musical – in particular, one must style it, orchestrate it, give it rhythm, and – should the occasion arise – make local modifications. At this stage, *Kanthume*, an *Open Music*'s library that permits the quantification of a chord sequence (such as the one illustrated in Figure 2) in rhythmic notation and traditional metric, would have proved effective. However, I prefer to perform this transcription/quantification by hand, despite the slowness of the work, printing the chord sequence onto graph paper and then copying it again slowly. In fact, it is this manual operation that permits me to understand, to control – in short, to listen to this primary material with my inner ear, in order to render it musical subsequently.

209

209

Chaque note, accompagnée de sa morphologie propre, ([si b sec], [fa 1/4 de b 3 notes répétées], [ré 1/4 de b flat], [sol 1/4 de # son à l'env], etc...) doivent s'entendre comme autant de voix indépendantes et homogènes d'un contrepoint de sonorités.

G 7122 B

Fig 4. Hérédoribotes, for solo viola and 51 orchestra musicians, realisation of cloud of pulsated points (mes. 209 à 213, Billaudot publisher).

This technical presentation of a use of *Open Music* will appear naïve to some. The applications of this software can be more complex, in my personal use (calculation by *Open Music* of “first spectra”, calculation of “iterated harmonic transpositions”, representation by “vectors of *Tanner*”, software *Pareto*⁶). The issue here, however, is to outline the stages that proceed from the elaboration of a technique that arose from aesthetic preoccupations up to the point of its formalisation and “normal” – almost normative – application. The concern here is also to show that in a simple case, even when the formalisation of the patch is easy and makes the work less arduous, it is more important to make use of the slower pace of pen and ink and manual calculation.

Open Music is a tool for symbolic calculation of the musical that is extraordinary due to its interface as well as for its unmatched freedom, and by permitting one to free oneself of certain constraints imposed by calculations in order to concentrate better on musical quality. To conclude, let it be clear, however, that *Open Music* remains a tool for calculation of classical musical categories (pitch, duration, dynamic, parameters midi) that arise from categories of western musical writing established by Boethius, Hucbald de Saint-Amand, Guido d’Arezzo and Franco of Cologne between the sixth and thirteenth centuries. With the appearance of recording technologies at the beginning of the twentieth century and of its deployment as *archi-writing*, to use Derrida’s expression, from the 50s on by composers of *musique concrète* and of electro-acoustic music, complex sound has become an essential category of recent music. Today, numerical means of increasing capability open the way to a symbolic approach to thinking about complex sounds, which still lack means of clear and ergonomic semiotic representation for composition (Lévy, 2002). One can hope, nevertheless, that in the near future a tool for “the composition of complex sound” will appear that brings together the possibilities of sound transformations software such as *Protools*, *Max*, or *Logic Audio* and the capacities for high-level symbolic calculation such as *Open Music*.

REFERENCES

Lévy, Fabien (2002), « L’écriture musicale à l’ère du numérique », *Culture & recherche* n° 91-92, *Musique et son: les enjeux de l’ère numérique*, Ministère de la Culture, mission de la recherche, July 2002, also downloadable on: http://www.culture.fr/culture/editions/r-cr/cr91_92.pdf

Lévy, Fabien (2004), *complexité grammatologique et complexité aperceptive en musique. Etude esthétique et scientifique du décalage entre la pensée de l’écriture et la perception cognitive des processus musicaux sous l’angle des théories de l’information et de la complexité*. Ph.D in music and musicology of XXth Century, Ecole des Hautes Etudes en Sciences Sociales, Paris, February 2004, also downloadable on: <http://www.ircam.fr/equipes/repmus/Rapports/TheseFabLevy.pdf>

Software PARETO downloadable on: <http://membres.lycos.fr/fabienlevy/Pareto.html>

Stockhausen, Karlheinz (1957), « Wie die Zeit vergeht », in *die Reihe*, T.III, Herbert Eimert éd., Vienne, 1957.

⁶ Pareto – [Patch d’Analyse et de Resynthèse des Echelles dans les musiques de Tradition Orale] (*Patch of Analysis and Resynthesis of Scales in musics of Oral Tradition*) is a software programmed on *Open Music* that assists in the determination of scales of pitches in the musical repertoires of oral traditions. Once the chart of virtual fundamentals from a sound file has been extracted by software such as *Diphone*, *Audiosculpt*, etc. and imported into *Open Music* in the form of a text file, Pareto evaluates the average scale of the motif with statistical tools of averaging and temporal smoothing. Then, in order to confirm that the average scale thus determined makes sense to the musicians, it’s possible in Pareto to transform the initial sound file by microtransposition via *SVP* according to precise hypotheses about the scales (hypotheses of different scales, an hypothesis calculated to confirm by auditory consent, “placebo” scales,...), in order to offer it to the musicians again. Pareto was used for the first time in July 2000 in Cameroon, at the time of an ethnomusicological mission with the Bedzan pygmies. More information on <http://membres.lycos.fr/fabienlevy/Pareto.html>